

M O D E L
579_{EV}



© 2024 PACCAR Inc. - All Rights Reserved

This manual illustrates and describes the operation of features or equipment which may be either standard or optional on this vehicle. This manual may also include a description of features and equipment which are no longer available or were not ordered on this vehicle. Please disregard any illustrations or descriptions relating to features or equipment which are not on this vehicle. PACCAR reserves the right to discontinue, change specifications, or change the design of its vehicles at any time without notice and without incurring any obligation. The information contained in this manual is proprietary to PACCAR. Reproduction, in whole or in part, by any means is strictly prohibited without prior written authorization from PACCAR Inc.

579EV

Contents

- Safety 6
- Emergency 16
- Controls..... 22
- Operation..... 32
- Maintenance 40
- Information 50

Safety

SAFETY

Applies To 579EV



This is the operator's manual for the Model 579EV, a battery electric vehicle. Because this truck does not have an internal combustion engine, the 579EV powertrain and auxiliary components require different operating procedures and service intervals than the Model 579.

This supplemental operator's manual provides information on electric vehicle components, operations, and safety warnings that are different from or not included on the Model 579 internal combustion engine chassis.

Please refer to the Model 579 operator's manual included with this truck for information on components, operations, and safety warnings that are shared between the battery electric chassis and the internal combustion engine chassis.

Using this Manual

Please take time to become acquainted with your vehicle by reading this operator's manual. Peterbilt strongly recommends that you thoroughly read and understand the manual before operating the 579EV. This manual contains useful information for the safe and efficient operation of the 579EV. It also provides some service information, including safety checks and basic preventative maintenance inspections.



NOTE

After you have read this manual, store it in the glovebox for the next truck operator or the next owner.

Your vehicle may not be equipped with certain features or options mentioned

in this manual. Therefore, you should pay close attention to the instructions that pertain to just your vehicle. Additionally, if your vehicle is equipped with special equipment or options not discussed in this manual, consult your dealer or the manufacturer of the equipment. All information contained in this manual is based on the latest production information available at the time of publication. Peterbilt Motors Company reserves the right to make changes at any time without notice.

Safety Alerts

Please read and follow all safety alerts contained in this manual. They are provided for your protection and information. These alerts can help you avoid injury to yourself and your passengers. These instructions can also help prevent costly damage to the

vehicle. Safety alerts are highlighted by the safety alert symbols and signal words such as "DANGER," "WARNING," "CAUTION," or "NOTE." Do NOT ignore any of these alerts.

Dangers



The safety message following this symbol and signal word provides a warning against operating procedures that, if not avoided, will cause injury or death. They could also cause equipment or property damage. The alert will identify the hazard, how to avoid it, and the probable consequence of not avoiding the hazard.

SAFETY

Warnings



The safety message following this symbol and signal word provides a warning against operating procedures that, if not avoided, could cause injury or death. They could also cause equipment or property damage. The alert will identify the hazard, how to avoid it, and the probable consequence of not avoiding the hazard.

Cautions



The safety message following this symbol and signal word provides a caution against operating procedures

that, if not avoided, could cause equipment or property damage. The alert will identify the hazard, how to avoid the hazard, and the probable consequence of not avoiding the hazard.

Notes



The message following this symbol and the signal word provides important information that is not safety related but should be followed. The alert will highlight information that may not be obvious but is useful to your efficient operation of the vehicle.

Illustrations

Some illustrations in this manual are generic and do NOT exactly match the

powertrain or parts used in your application. The illustrations can contain symbols to indicate an action required and an acceptable or unacceptable condition. The illustrations show service procedures. The procedure will be the same for all applications, although the illustration may differ.

General Safety Instructions

Important safety notices about operating and servicing your vehicle are included in this section.

California Proposition 65 Warning

- Low voltage battery posts, terminals, and related accessories contain lead and lead compounds, which are chemicals known to the State of California to cause cancer

and reproductive harm. Wash hands after handling.

- Other chemicals in this vehicle are also known to the State of California to cause cancer, birth defects or other reproductive harm.

Data Recorder

California Vehicle Code – Section 9951
– Disclosure of Recording Device

Your vehicle may be equipped with one or more recording devices commonly referred to as “event data recorders” (EDR) or “sensing and diagnostic modules” (SDM). If you are involved in an accident, the device(s) may have the ability to record vehicle data that occurred just prior to and/or during the accident. For additional information on

your rights associated with the use of this data, contact:

- The California Department of Motor Vehicles – Licensing Operations Division
- <http://www.dmPage 11v.ca.gov/>

Environmental Protection Agency (EPA)

Below is information on the use and disposal of hazardous materials.

Some chemicals in the hydraulic oil, transmission oil, axle oil, coolant, propulsion battery packs, refrigerant, refrigerant lube, lead acid batteries, etc. may contaminate the environment if spilled or improperly disposed of.

Contact your local government agency for proper disposal guidelines.

A Special Word about Repairs

Before performing any repair, read and understand all safety precautions and warnings. The following is a list of general safety precautions that must be followed to provide personal safety. Failure to follow these instructions may cause injury or death. Special safety precautions are included in the procedures when they apply.



WARNING!

Do not attempt repair work without the proper training, service manuals, and tools. You could be injured, killed, or make your vehicle unsafe. Only conduct tasks that you are qualified to perform.

SAFETY



WARNING!

Only allow qualified service technicians to work on this vehicle. Improper practices, carelessness, or ignoring any warnings could cause death, personal injury, and equipment or property damage.



CAUTION!

The installation of electronic devices on any of the vehicle Controller Area Networks (CAN) or their associated wiring is not permitted and could adversely affect vehicle performance and cause vehicle fault codes to be recorded. These modifications could also void the vehicle warranty.

Even a well-maintained vehicle must be operated within the range of its mechanical capabilities, electrical capabilities, and load rating limits. See the Weight Ratings label on the driver's door edge.



WARNING!

Modifying your vehicle can make it unsafe. Some modifications can affect your vehicle's electrical system, stability, or other important functions. Before modifying your vehicle, check with your dealer to ensure the modification can be performed properly. Improper modifications could cause injury, death, or equipment damage.

Every new vehicle is designed to conform to all Federal Motor Vehicle Safety Standards that were applicable at the time of manufacture. Even with these safety features, continued safe and reliable operation greatly depends upon regular vehicle maintenance.

Follow the maintenance recommendations found in the Preventative Maintenance section. This will help preserve your investment in the 579EV.

Take your vehicle to an Electric Vehicle (EV) Service Certified Dealer for repairs.

Properly maintained high voltage personal protective equipment is required. If you are not a qualified technician for the 579EV, leave all repairs to an authorized service facility.

Authorized service facilities are equipped to perform repairs safely and correctly.

Additional Sources of Information

Major component suppliers also supply operator's manuals specific to their products. Additional manuals and other pieces of literature are included in the glove box literature package.

Safe Vehicle Operation



WARNING!

Vehicle noise may be reduced in some operation modes. The vehicle operator must remain aware of nearby vehicles or pedestrians at all times. Failure to comply may result in death, injury, or property damage.

Refer to the *579 Operator's Manual* for more guidance on safe driving.

Vehicle Loading

Refer to the *579 Operator's Manual* for guidance on loading the vehicle.

Battery Electric Truck Parts

Description

Air Compressor

The air compressor is driven by an electric motor.

Air Conditioning Compressor

The air conditioning compressor is also driven by an electric motor.

Cab Heater

The cab heater uses energy from the propulsion battery pack for the cab heating. It heats up coolant that

circulates through a heater core for the cab.

Charger

This truck is equipped with a DC fast charger and has an optional AC charger. The charger inlet is located on the driver's side on the propulsion battery pack.



CAUTION!

Use a compatible charger when charging the propulsion battery pack. Noncompatible chargers may not charge the truck, which could negatively affect the propulsion battery pack life.

SAFETY

Chiller

The chiller maintains the optimal battery operation temperature threshold by circulating chilled coolant through the battery packs.

Coolant Pumps

Coolant pumps are used to circulate the coolant through several coolant loops on the 579EV.

DC-DC Converter

The DC-DC converter is the battery electric truck's equivalent to a diesel truck's alternator. The DC-DC converter uses energy from the propulsion battery pack to power the low voltage components such as controllers and lights and charge the low voltage battery.

eAxle Differential

Each eAxle is equipped with a differential gear reduction and a wheel end reduction.

eAxle Transmission

Each eAxle has a 2-speed transmission.

Power Steering Pump

The power steering pump is driven by its own motor.

Powertrain Fan

The powertrain fans are driven by their own electric motors.

Propulsion Motor and Inverter

Each eAxle has one propulsion motor and inverter. The inverter converts DC voltage into time-averaged pulses that approximate the AC voltage needed to drive the propulsion motors.

Propulsion Battery Packs

There are several high voltage propulsion battery packs on this truck. Careful maintenance and operation are required to maximize the propulsion battery pack life.



WARNING!

The 579EV contains sealed lithium-ion high voltage propulsion batteries. If the batteries are disposed of improperly, there is a risk of severe burns and electric shock resulting in serious injury or death.

Refer to [Vehicle Storage Instructions](#) for battery EV storage requirements.

Vehicle Layout

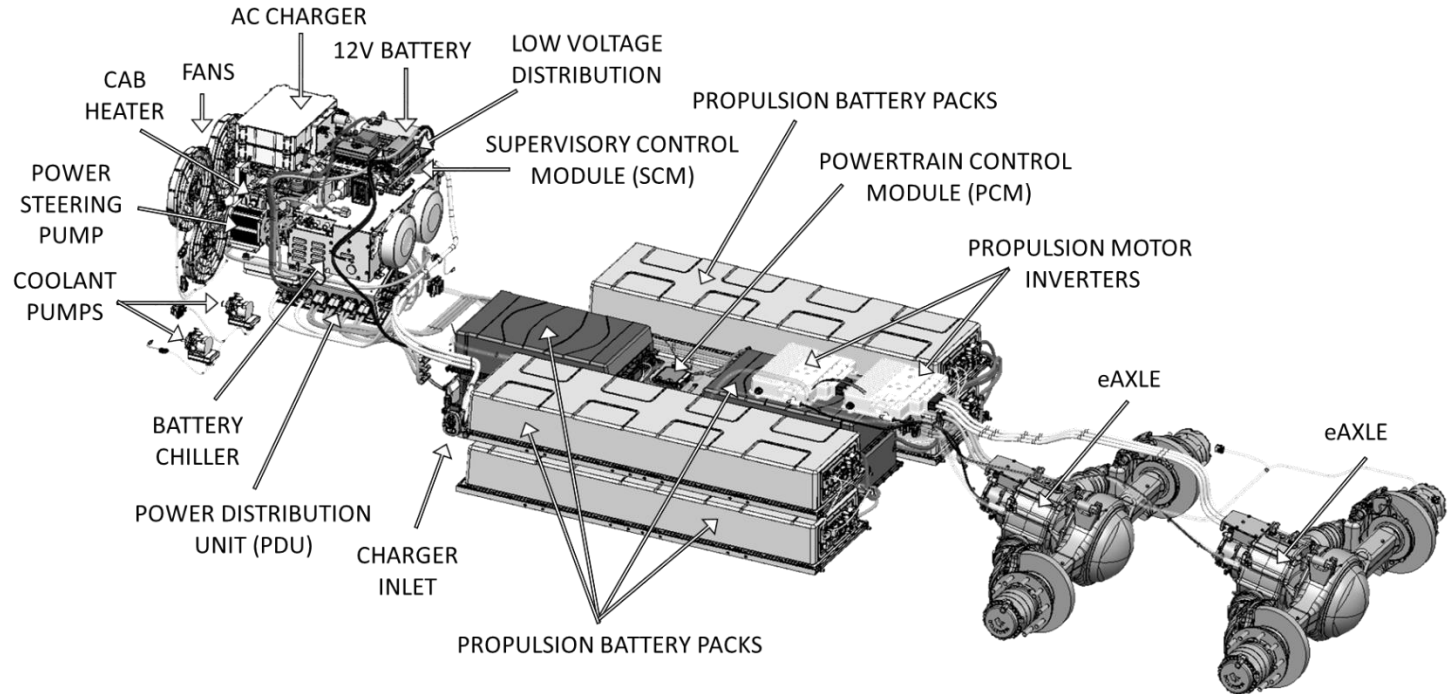

Additional PCAS Components

(PCAS: Power Electronics and Controls Subsystem)

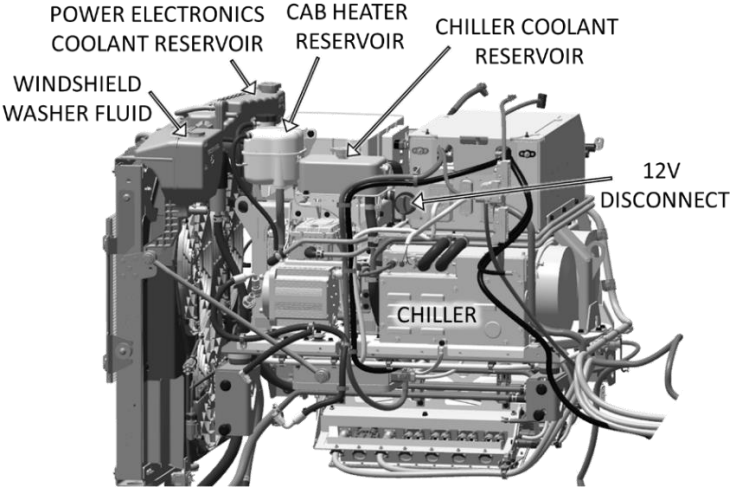

FRONT OF TRUCK

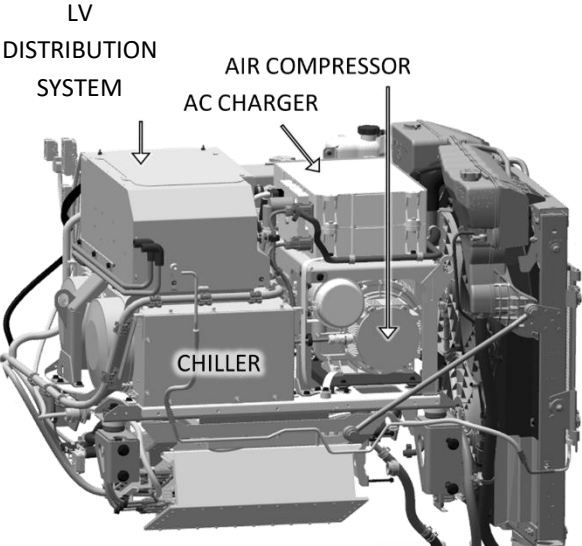

FRONT OF TRUCK

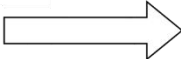

Emergency

EMERGENCY

Roadside Assistance

Call toll-free to talk to someone at the PACCAR Customer Center.

1-800-4Peterbilt

(1-800-473-8372)

The Customer Call Center is open 24 hours per day, 365 days per year, and is staffed with trained personnel (English and other languages if necessary), free of charge, to provide total roadside assistance. Their custom mapping system can locate the nearest Authorized dealers and Independent Service Providers (ISPs) based on the vehicle's location. In addition, the customer center can dispatch services for tires, trailers, fines and permits, chains, towing, hazardous clean-up, mechanical repairs and preventive

maintenance services. If they cannot answer a specific question, they will direct you to a representative who can.

First Responders Guide

First Responder instructions are available through the QR below. Download and print the documentation for the Peterbilt 579EV with your current model year. Routinely check the NFPA site to ensure your first responder materials are up to date.



**First Responders Field Guide
QR Code (Scan with Phone
Camera to Navigate to URL)**

<https://www.nfpa.org/Education%20and%20Research/Emergency%20Response/Emergency%20Response%20Guides/Peterbilt?l=78>

Emergency Procedures

If an accident occurs, follow the below steps:

1. If possible, park the truck and remove the key from the ignition.
2. If there is an emergency, call 911 immediately.
3. If the vehicle is on fire, do NOT try to extinguish the fire. Per NFPA guidelines, move at least 100 feet upwind of the fire.

Provide First Responders with the First Responders Field Guide or point first responders to the First Responders label with a QR code.

How to Jack an Electric Vehicle

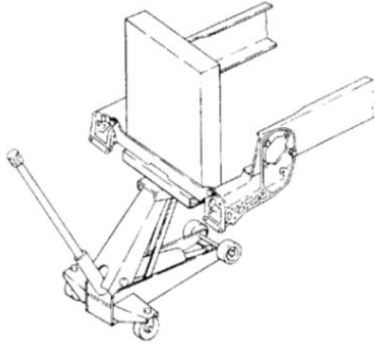

WARNING!

When jacking or lifting a vehicle, do not place the jack or hoist on or within 12" of any high voltage components or orange high voltage cables. Failure to follow this warning could result in injury, death, or equipment damage.

When jacking the front end of a vehicle, place the jack at the center of the steer axle and then lift the vehicle.

When jacking the back end of a vehicle, place the jack at the center of the rear differential housing.



CAUTION!

To avoid placing stress on vehicle components, do not lift from the belly plate. Failure to comply may result in equipment or property damage.

Towing



WARNING!

Do not tow this truck after an accident if high voltage components were damaged. Refer to the first responders field guide for more instructions on towing. Failure to comply may result in injury, death, or equipment damage.



WARNING!

Do not allow the propulsion motors to spin while towing this truck to avoid generating unsafe voltage. Failure to comply may result in injury, death, or equipment damage.

EMERGENCY

CAUTION!

Always put the transmission in neutral and remove the axle half shafts before towing. Failure to comply may result in equipment or property damage.

NOTE

All drive axles on these trucks contain diff lock hardware, even when there are no diff lock switches on the dash. The cage bolt must be used on drive axles when preparing the truck for wheels-on-ground towing.

The 579EV can be transported one of two ways. The first is on a lowboy trailer with all wheels off the ground.

If it is not possible to tow off the ground, the vehicle may be towed with all wheels on the ground using the following steps.

Wheels-on-the-Ground Towing

1. Put the transmission in neutral.
2. Remove the keys from the ignition.
3. Turn the low voltage disconnect to the OFF position.
4. Always use the diff lock cage bolts.
5. Remove all drive axle half shafts.

Scan the QR code with a phone camera to read more detailed towing instructions.



**Accelera Towing Procedure for
ePowertrain Manual**

https://graphicvillage.org/meritor/TP2_314.pdf

How to Charge a Dead LV Battery

DANGER!

Do not connect any components to the propulsion battery packs. Failure to comply will result in personal injury, death, or equipment damage.



WARNING!

Absorbent Glass Mat (AGM) batteries contain lead acid, which can burn a person on contact, and explosive gasses. Ignoring safety procedures may result in death, personal injury, equipment, or property damage.

Do not jumpstart the LV batteries when all usable energy in the battery is depleted.

Instead, remove the battery from the vehicle and see the battery's original manufacturer's manual for off-vehicle charging instructions.



NOTE

The maximum on-vehicle charge rate for LV batteries is 10 amps.

Recovering a Vehicle



WARNING!

Always perform the vehicle shutdown steps before recovering the vehicle. If not properly keyed off, the vehicle may unexpectedly move. Failure to follow this warning could result in injury, death, or equipment damage.



WARNING!

Never place chains or straps on or across any electric cables or components. Failure to follow this warning could result in injury, death, or equipment damage.



WARNING!

When jacking or lifting a vehicle, do not place the jack or hoist on or within 12" of any high voltage components or orange high voltage cables. Failure to follow this warning could result in injury, death, or equipment damage.

EMERGENCY

Follow the steps in the first responders field guide for recovering a vehicle from a precarious position.

Fuse Replacement

Follow the steps in the *579 Operators Manual* for replacing fuses. Refer to [Additional PCAS Components](#) for the location of the low voltage fuses for the battery electric truck components.

Controls

CONTROLS

Vehicle Cluster

This section contains information on the battery electric vehicle cluster, switches, and HVAC.

For reference, the 579EV cluster is shown below. Each new gauge and telltale is described in the following section. The speedometer will either have MPH or KPH as the primary unit, but otherwise remains the same.



Gauges in the Center Cluster

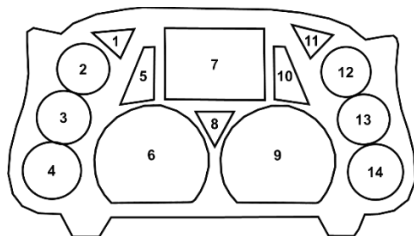

Location Descriptions:

1. Telltales Only
2. Coolant Gauge
3. Auxiliary Power Loss Gauge
4. Charge Level Gauge
5. Telltales Only
6. Power Output Gauge
7. TFT Display
8. Telltales Only
9. Speedometer
10. Telltales Only
11. Telltales Only
12. Motor Torque Available Gauge

13. Primary Air Pressure Gauge
14. Secondary Air Pressure Gauge

Telltales

Ready to Move



Location: 9

Color: Green

Purpose: This telltale illuminates when the truck is ready to move. The truck could move if the accelerator pedal is pressed.

PTO



Location: 9

Color: Green

Purposes: This telltale illuminates when the electric PTO (ePTO) is enabled.

External Plug Connect



Location: 5

Color: Green

Purposes:

1. This telltale illuminates when the truck is plugged into a charger.
2. This telltale flashes and an audible alarm will sound if a driver attempts to drive off while the truck is plugged into a charger. An interlock prevents the truck from driving during charge sessions.

CONTROLS



WARNING!

Ensure the park brake is engaged before connecting the truck to a vehicle charger. Failure to engage the park brake before connecting the charger cable could result in injury, death, or equipment damage.

Service



Location: 1

Color: Amber (Yellow)

Purpose: This telltale illuminates when the truck needs to be serviced or permanent damage could occur.

Stop Powertrain



Location: 8

Color: Red

Purpose: This telltale illuminates when the truck needs to be pulled over. Failure to stop the truck could result in injury, death, or permanent damage to the truck.

Limited Performance Mode



Location: 5

Color: Amber (Yellow)

Purpose: This telltale illuminates to inform the operator that the vehicle has entered limited performance mode. Maximum vehicle torque or

speed is reduced, and soon after, the vehicle will completely shut off.



NOTE

This telltale is a standard indication of low vehicle charge. Operators who drive the vehicle to 0% state of charge should see this telltale. When it illuminates, find a safe place to pull over and shutdown the vehicle.

Regenerative Braking System



Location: 6

Color: Amber (Yellow)

Purpose: The RBS telltale illuminates when the propulsion battery is at a high state of charge, meaning that the Regenerative Braking System (RBS) is severely derated or disabled. This may occur due to abnormal operating conditions (such as extreme ambient temperatures or when a fault occurs). For more information on the RBS, see [Regenerative Braking Switch](#) on page 28.

When the RBS telltale is activated, the operator must use the service brakes. The truck may be driven while the RBS telltale is activated if the Service

Telltale and Stop Telltale are both deactivated.



WARNING!

The Regenerative Braking System (RBS) is limited in its ability to slow the vehicle as the propulsion battery approaches a full state of charge. Since the RBS telltale may not illuminate, be aware of the propulsion battery state of charge. If either the RBS telltale is activated or the propulsion battery pack is above 95% state of charge, the operator must use the service brakes to slow the vehicle. Failure to comply may result in injury, death, or property damage.

High Voltage Hazard



Location: 9

Color: Red

Purpose: This telltale illuminates when there is a high voltage hazard such as “High Voltage Interlock Loop Broken” or “Isolation Resistance Too Low”. If this telltale illuminates, find a safe place to pull over, shutdown the truck, and call the PACCAR Customer Center.

Power Output Gauge

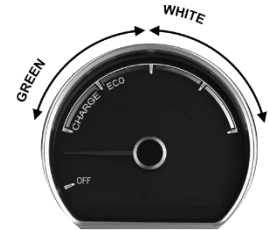

CONTROLS

Location: 6

Purpose: This gauge helps drivers determine if their driving is economical (ECO) or resulting in regenerative braking, charging (CHG). Driving with the needle in the green ribbon region (CHG and ECO) will result in increased range. Driving with the needle in the white ribbon region will result in lower range.

When the truck is ready to move, the needle will move between “CHG” and “ECO” and the green Ready to Move telltale will illuminate.

Propulsion Battery Gauge (State of Charge)

This gauge is labeled “BATTERY.”



Location: 4

Purpose: This gauge provides the propulsion battery pack’s state of charge. When the gauge reads 0%, the truck will enter limited performance mode.

Aux Loss Gauge



Location: 3

Purpose: This gauge shows the power consumed by auxiliary components. Auxiliary component power consumption is considered any power that is not consumed by the propulsion motors.

When the needle is within the green region, the truck’s range should not be significantly impacted by power loss. If the gauge value is above the green region, the driver may consider turning off or reducing power consuming units such as the HVAC.

Motor Torque Available Gauge



Location: 12

Purpose: This gauge shows the torque available.

Heating and Air Conditioning

Heating and Air Conditioning switches have the same functions for both diesel and battery electric trucks.

Since this truck is powered by a battery electric powertrain, it does not generate enough waste heat to power the cabin heater. Instead, the propulsion battery pack's power is used

to heat the cab. It will take 1-2 minutes for the truck to start generating warmer air. Using the cab heater will reduce the truck's range.

 NOTE
<p>Set the HVAC in the recirculation mode to save energy and increase truck range.</p>

Dash Switches

Regenerative Braking Lever

The Regenerative Braking System (RBS) adds power back into the battery by automatically decelerating the vehicle when the accelerator pedal is released and the vehicle is moving. In battery electric vehicles, regenerative braking imitates defueled engine drag and engine brake levels. The RBS

functionality is allowed at lower truck speeds.

 NOTE
<p>Turn the regenerative braking lever ON to enable regenerative braking and maximize the truck range.</p>

Pulling the right-hand stalk (RHS) toward the driver increases the regenerative braking level, while pushing the RHS away from the driver reduces the regen level.

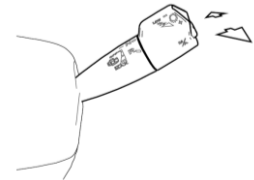

CONTROLS

When regenerative braking is on, the green indicator will turn on. The telltale has three dots that indicate the level of regen behavior.



The RHS allows the operator to control the regen behavior level. By pressing up on the RHS, the driver can move up a level of regen behavior. By pressing down on the stalk, the operator can move down a level of regen behavior.

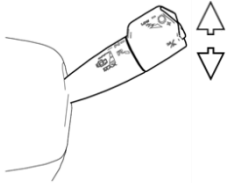

Level	Retarder Behavior
Off	No Regenerative Braking
1	Low Regenerative Braking Level
2	Medium Regenerative Braking Level
3	High Regenerative Braking Level (may be similar to Level 2 depending on truck options)

i **NOTE**

The higher the RBS level, the more regeneration is provided to the propulsion system.



NOTE

When the regenerative braking switch is OFF and 0% accelerator pedal demand occurs, the truck will coast with no braking effort from the propulsion motors.



WARNING!

Turn the regenerative braking ON/OFF lever to the OFF position when low traction road conditions exist (such as ice, rain, and gravel). Use the foundation brakes instead for optimal braking control. Failure to heed this warning could result in injury, death, or equipment and property damage.

Driver Controlled Differential Lock (DCDL) Switch

This switch activates the Driver Controlled Differential Lock (DCDL) located on the front and rear axles. The lock maximizes vehicle traction and control during unfavorable operating conditions.

The DCDL can be turned on or off only if the truck is standing still or moving at a constant, slow speed with level traction.

 WARNING!
Do not turn on the Driver Controlled Differential Lock (DCDL) when traveling on a road with an elevated grade. Failure to comply may result in a loss of vehicle stability, which could lead to death, injury, or equipment and property damage.

 CAUTION!
Do not turn on the Driver Controlled Differential Lock (DCDL) when the truck's wheels are slipping or losing traction. Failure to comply may result in damage to the axle or other equipment damage.

If the truck is losing traction, release the accelerator and ensure the truck returns to stable traction levels before turning on the DCDL.

 WARNING!
Do not exceed 25 mph (40.2 km/h) when using the Driver Controlled Differential Lock (DCDL). DCDL increases the truck's turning radius, which causes understeer. This may cause an operator to lose control of the vehicle. Failure to comply may result in death, injury, or equipment and property damage.

Gear Selector

This electric powertrain contains eAxle(s) with either 2-speed or 3-speed transmissions integrated on each eAxle.

CONTROLS

The right-hand stalk can be rotated to enter Drive, Neutral, or Reverse (see diagram below).

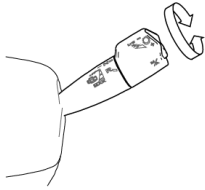

The truck must be in Neutral to turn on.

While the truck is charging, any attempt to enter Drive or Reverse causes an audible alarm to sound and the green External Cord Connect telltale to flash. Unplug the charger plug before driving the truck.



WARNING!

Do not exit the vehicle without first making sure the parking brake is engaged. The gear change lock does not stop the operator from releasing the parking brake before they exit the vehicle, which could result in the vehicle moving during the charge session. Failure to comply may result in death, injury, or equipment and property damage.

Operation

OPERATION

Pre-Trip Inspection

Engage the park brake and put the transmission in neutral before performing any checks.

Visual Inspection

Keep your vehicle in top operating condition before driving it. Inspect the vehicle according to the below lists.



WARNING!

Do not attempt to fix damaged high voltage components noted during the inspection. Only authorized technicians for the 579EV should conduct repairs. Failure to heed this warning could result in injury, death, or damage to the vehicle.

Truck Exterior

1. Check for low hanging cables below the truck, especially high-voltage cables. Have an authorized technician examine any questionable components and repair them without delay.
2. Ensure the wheel cap nuts are in place and torqued properly.
3. Ensure all tire pressures match and are in the recommended pressure range.
4. Check the parking spot for evidence of any leaking fluids.
5. Verify that the truck exterior lights are all functioning.
6. Ensure all windows, mirrors, and lights are clean and unobstructed.

PCAS Inspection (Located Under Cab)



WARNING!

Do not attempt to check the coolant level when it is still hot. Failure to heed this warning could result in personal injury due to scalding coolant.



WARNING!

Only visually inspect high voltage components. Failure to follow this warning could result in injury or death if high voltage components are loose or damaged.

1. Verify that the coolant lines, power steering lines, air lines, fittings, and other connections

- are all secure, intact, and free of chafing.
2. Verify all three of the coolant reservoirs are properly filled.
 3. Ensure the radiator fan is free of debris.

See Also

[Maintenance Schedule](#)

Startup

1. Remove the charger plug if connected.
2. Turn the ignition key fully clockwise and let it spring back.
3. Ensure the retarder switch is in the ON position (unless inclement driving conditions exist) to maximize truck range.
4. Push the park brake to ensure it is released.
5. Put the truck in drive.

6. The truck will be ready to move when the green Ready to Move telltale is illuminated.



**Ready to Move Telltale
(Green)**



WARNING!

Pull over if the Stop Lamp is present. Continuing to discharge the battery pack after the Stop Lamp is present could permanently damage the battery pack and stop the truck unexpectedly. Failure to comply could result in death, injury, or property damage.



WARNING!

Turn the retarder switch to the OFF position during low traction road conditions (such as ice, rain, and gravel). Failure to turn OFF the retarder could result in uncontrolled skidding. Failure to comply could result in death, injury, or property damage.



WARNING!

Do not assume the truck is OFF when it is silent. Check if the Ready to Move telltale is illuminated. Failure to comply could result in death, injury, or property damage.

OPERATION



WARNING!

Vehicle noise may be reduced in some operation modes. The vehicle operator must remain aware of nearby vehicles or pedestrians at all times. Failure to comply may result in death, injury, or property damage.



NOTE

Closely monitor the cluster telltales for derate information (physical telltales) and instructions to pull over (digital Stop Sign telltale). Failure to monitor the telltales could result in permanent damage to the truck powertrain.



NOTE

Stay within the green region of the power output gauge to maximize truck range.

Shutdown

1. Put the truck in neutral.
2. Pull the park brake to ensure that it is applied.
3. Remove the key from the ignition.
4. Ensure the Ready to Move telltale is extinguished.

Park Brake Position

For reference, drawings of the park brake knob in its released position (park brake disengaged) and applied position (park brake engaged) are provided below.

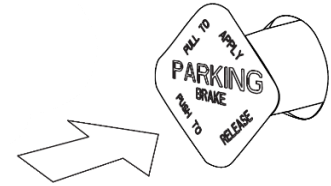

Push to Release Park Brake



Pull to Apply Park Brake

Charge Port Description

The 579EV has a DC fast charger and an optional AC charger. Both are SAE J1772 compliant. The CCS1 charge port is located on the driver's side on the propulsion battery pack. Use the Charge Port LED (next to the truck's charge port) and the charger's interface to monitor the charging status.

Charge Port LED Status:

LED Color	Charger Status
Flashing Green	DC Fast Charging in Progress
Solid Green	Charging Complete
Flashing Green Then Flashing Yellow	AC Charging in Progress (No Errors)
Solid Yellow	Charger Plug Needs to be Reconnected
Flashing Red Then Flashing Yellow	DC or AC Charge Rate Severely Limited
Flashing Red	Charging Error

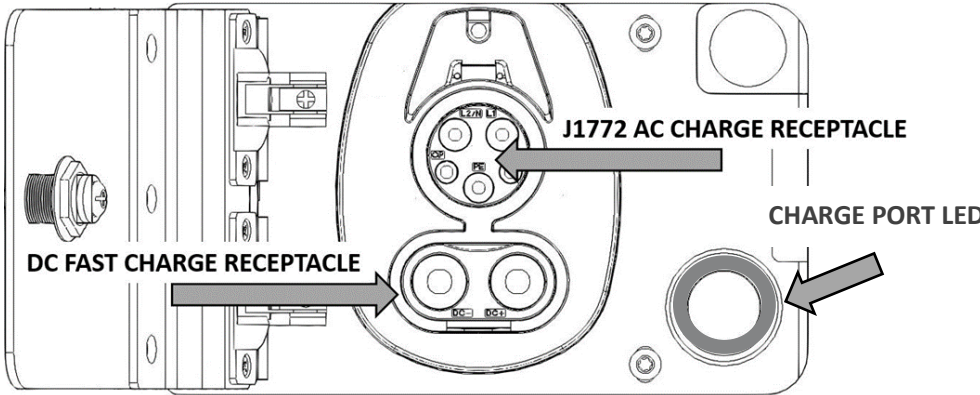

OPERATION

Initiating Charging



WARNING!

Ensure the park brake is engaged before connecting the truck to a vehicle charger. Failure to engage the park brake before connecting the charger cable could result in injury, death, or equipment damage.

1. Engage the park brake.
2. Put the truck in neutral.
3. Leave the low voltage disconnect in the ON position.
4. Plug in the charger.
5. Wait until the charge port LED shows the DC or AC charging status (see Charge Port LED Status table).



NOTE

For optimal performance and range, frequently charge the high voltage batteries to 100% state of charge, preferably at least once per week.

Charging Errors



WARNING!

Do not cycle the low voltage disconnect without confirming that the vehicle is not charging. Failure to comply will result in injury, death, or equipment damage.

If the charge port LED shows a charging error by flashing red and will not release the charge handle, do the following:

1. Use the vehicle-side stop button to request a stop charge.
2. Verify the charger says “not charging.”
3. Cycle the low voltage disconnect on the vehicle.

Disconnecting Charger

The charge port LED will have a solid green illumination (no flashing) when 100% state of charge has been reached.

If you need to remove the charge plug before reaching 100% state of charge, press the Charge Port LED/button to end the charge.

If the charger plug has a button, you may need to press the charger plug button to disengage it.

Idle Shutdown

This truck comes equipped with an automatic shutdown. If the truck is left on idle for longer than 45 minutes, the vehicle will turn off.

If idle shutdown occurs, the stop engine lamp will illuminate on the dash. The truck must be turned off and allowed to sit for 15 seconds before it can be turned on again.

Since the idle shutdown does not turn off the entire low-voltage system, the truck will continue to slowly drain the low voltage battery until the truck is turned off.

 CAUTION!
If a shutdown occurs, the truck will slowly drain the low-voltage battery. Drivers who suspect a shutdown should always check the truck's power levels before operation. Failure to comply may result in an increased risk of low power, which may lead to equipment damage.

 CAUTION!
Do not use the emergency cut-off button except during an emergency. Stopping a charge session through any method other than with the truck's Charge Port LED/button may damage the contactors. Failure to comply may result in equipment damage.

Emergency Cut-Off

Each charger has an emergency cut-off button that can be used to stop a charge session. This should only be used in the case of an emergency.

OPERATION

Maintenance

MAINTENANCE

Daily Checks

The driver should perform these checks of the vehicle daily, at a minimum.



NOTE

These checks are in addition to, not in place of, Federal Motor Carrier Safety Regulations. These regulations may be purchased by writing to the Superintendent of Documents U.S. Government Printing Office Bookstore 710 North Capitol Street N.W. Washington, DC 20402 or ContactCenter@gpo.gov.

Powertrain

- All Coolant Levels
- Power Steering Fluid
- Low Voltage Battery Cables
(including a visual inspection

of the orange high voltage cables)

- Check for signs of chafing or rubbing.
- Ensure all clamps or zip ties holding the cables are in good condition.
- Hood Latch
- Brake Lines and Hoses
- Steering Components



WARNING!

Do not attempt to physically inspect any high-voltage components. Perform a visual check instead. For high-voltage component problems, contact your nearest battery electric vehicle dealership. Failure to comply may result in death, injury, or equipment and property damage.

Chassis and Cab Exterior

(See 579 Operator's Manual)

Note and replace any damaged labels.

Cab Interior

(See 579 Operator's Manual for non-battery electric vehicle components)

- Battery Gauge: Ensure the state of charge is high enough to complete your drive cycle.
- Cluster
 - Ensure the needles move through their full range of motion during the instrument check procedure.
 - Ensure the usual telltales are illuminated during the lamp check.

Maintenance Schedule



DANGER!

Restrict high voltage system maintenance to qualified personnel only. Do not touch high voltage parts or attempt to remove high voltage parts. Do not attempt to service high voltage parts. Ignoring this warning will create risk of injury or death to yourself and bystanders.



WARNING!

Exercise extreme caution to prevent neckties, jewelry, long hair, or loose clothing from catching in the fan blades or any other moving parts. Failure to comply may result in personal injury, death, and equipment or property damage.



WARNING!

Key off the truck and wait until all radiators are cool before checking the coolant levels. Personal injury could occur if this warning is not followed.



WARNING!

Always perform the vehicle shutdown procedure before performing routine maintenance. If not properly keyed off, the vehicle may move quietly and unexpectedly. Failure to comply could result in death, injury, or property damage.



WARNING!

Only use approved air conditioning (A/C) oil as listed in the maintenance chart or on the vehicle's A/C service information label. Use of the wrong oil may lead to malfunction of the high voltage isolation in electric A/C compressor that could cause personal injury, death, or equipment or property damage.

MAINTENANCE

CAUTION!

Do not mix different brands or types of lubricants. Drain or remove old lubricants from the unit before refilling it with the specified lubricant type. Incorrect lubricant types may result in isolation errors, which make the vehicle inoperable. Failure to comply may result in equipment or property damage.

CAUTION!

Only use the recommended oil, and do not mix recommended oils with other lubricants. Failure to comply may result equipment or property damage.

CAUTION!

Do not perform welding procedures on the truck. Welding could damage the heat-treated rails, the high voltage insulation, controllers, and other expensive or safety critical components.

CAUTION!

Connecting to an unapproved CAN bus may trigger CAN fault codes or damage systems and components on the vehicle. Failures and damages caused by improper CAN bus connections are not covered by PACCAR warranties.

NOTE

Since the automatic transmission fluid (ATF) is used by the transmission and wheel end assemblies, the ATF will not reach the fill port. To fill, measure the fluid in the fill port and replace as needed. See [Towing](#).

NOTE

The coolant gauge telltale will turn on to indicate when a coolant reservoir needs more coolant. This telltale does not specify which reservoir is low.

MAINTENANCE

System	Type of Fluid	Capacities	Service Interval
Cab Heater	TRP Extended Life Coolant 50/50	1.25 gallons (4.7L)	2 years
Radiator		10.25 gallons (38.8L)	
Propulsion Battery Pack (ESS)		To Centerline of Reservoir Sight Glass	
Cab A/C	Polyol ester oil (RL68H preferred)	120 mL POE oil	As needed
	R134a	3.0 lbs	
Power Steering	Automatic Transmission Fluid (ATF) Dexron III	2.5 quarts (2.4L)	First 15,000 miles. Then every 120,000 miles or every year
ePowertrain Transmission	75W-90 Full Synthetic (Castrol Syngear, BASF Emgard 2986 FE)	1.1 quarts (1L)	50,000 miles
Axle Housing		8.45 qt (8L)	
Wheel End Assembly		0.79 qt (0.75L)	50,000 miles
Air Compressor Shaft	NLGI grade II/GC-LB	Lubricate the bearing	36,000 miles
Air Compressor	N/A	Replace both filters	20,000 miles

MAINTENANCE

Component Inspection Intervals



WARNING!

If any issues involving the high-voltage electrical system are discovered, DO NOT drive the vehicle. Contact an authorized EV Certified Dealer for assistance. Failure to comply may result in death, personal injury, equipment damage, or property damage.



WARNING!

DO NOT attempt to diagnose or correct vehicle issues. Please contact or take your vehicle to an authorized EV Certified Dealer for assistance. Attempting to diagnose or correct vehicle issues may result in death, personal injury, equipment damage or property damage.





WARNING!

DO NOT touch or attempt to remove any of the orange high-voltage cables, connectors, or components for any reason. If asked to inspect a high-voltage component or cabling, only inspect visually. Failure to comply may result in death or personal injury.

Component	Description	Inspection Type	Interval
High Voltage Cables	Verify integrity of cables - look for signs of wear and tear.	Visual	Once a year or during regular scheduled truck maintenance
HV and Phase Cable Glands	Validate that the cable glands are still sufficiently tightened.	Visual	Once a year or during regular scheduled truck maintenance

MAINTENANCE

Component	Description	Inspection Type	Interval
HV Cable Connectors	 WARNING!	Mechanical	Once every two years
	Do not attempt this inspection unless you are a Peterbilt technician with a Battery Electric Vehicle (BEV) Level Three certification. Failure to comply will result in death, injury, or property damage.		
Phase Cables	Verify integrity of cables - look for signs of wear and tear.	Visual	Once a year or during regular scheduled truck maintenance
Phase Cable Connectors	 WARNING!	Mechanical	Once every two years
	Do not attempt this inspection unless you are a Peterbilt technician with a Battery Electric Vehicle (BEV) Level Three certification. Failure to comply will result in death, injury, or property damage.		
Encoder and Thermal Cables	Verify integrity of cables - look for signs of wear and tear. Verify that connectors are properly torqued.	Visual	Once a year or during regular scheduled truck maintenance
Coolant In/Out (Inverter)	Verify tubes for coolant leaks at entry and exit points.	Visual	Once a year or during regular scheduled truck maintenance

MAINTENANCE

Component	Description	Inspection Type	Interval
Coolant In/Out (Motor)	Verify tubes for coolant leaks at entry and exit points.	Visual	Once a year or during regular scheduled truck maintenance
Ground Location (Inverter)	Ensure ground is securely fastened.	Visual	Once a year or during regular scheduled truck maintenance
Ground Location (Motor)	Ensure ground is securely fastened.	Visual	Once a year or during regular scheduled truck maintenance
Drive (Inverter)	Verify for overall component damage.	Visual	Once a year or during regular scheduled truck maintenance
Air Vent	Verify the level of dust accumulation and remove any obstruction.	Visual	Once a year or during regular scheduled truck maintenance
eAxle Mounts	Validate the integrity of the rubber mounts and verify that all the bolts are properly tightened.	Mechanical	Once a year or during regular scheduled truck maintenance
Inverter Mounts	Validate the integrity of the rubber mounts and verify that all the bolts are properly tightened.	Mechanical	Once a year or during regular scheduled truck maintenance
Coolant	Check coolant level. Add more if required.	Visual	During regular scheduled truck maintenance
Software	If requested, verify and change product software to the latest available version.	Software	As requested, once a year, or during regular scheduled truck maintenance.

Cleaning the Vehicle



WARNING!

Do not pressure wash any part of this vehicle. Failure to comply may result in injury, death, or equipment damage.



WARNING!

Perform the vehicle shutdown procedure before washing the truck. Failure to comply may result in personal injury, death, or equipment damage.



WARNING!

Do not wash the truck while it is charging. Do not wash the charge port, especially not while the truck is charging. Failure to comply may result in injury, death, or equipment damage.



CAUTION!

Ask the body builder for guidance on washing any equipment added by the body builder, especially high voltage equipment. Failure to comply may result in equipment or property damage.



CAUTION!

Do not get any harnesses, cables, or coolant routes wet. Failure to comply may result in equipment or property damage.

This vehicle's tractor and trailer (if attached) may be washed with normal, faucet-pressure water. This vehicle should not be pressure washed.



Avoid getting any part of the undercarriage wet, especially the areas where the battery systems and cables are housed.

MAINTENANCE

Vehicle Storage Instructions



CAUTION!

Failure to follow these guidelines may result in poor performance, and potentially unwarrantable repairs. Refer to your local Peterbilt dealership for the latest Storage maintenance and In-Service procedures.



NOTE

Following prolonged storage, there may be significant variation in the consistency of cells during initial operation causing a reduction in range. However, after running for two weeks, the BMS equalization function can help improve consistency and restore optimal range potential.

Battery EV Storage Requirements Summary		
Duration	Less than 15 days	15 days or longer*
SOC (State of Charge)	40%-100%	100%**
Environment	Well ventilated	
Ambient Temperature	Must stay within -31°F to 131°F (-35°C to 55°C)	
Parking Brake	Engaged	
Low Voltage (LV) Disconnect Switch	OFF position	

*If parked for 90 days	Drive truck once every 90 days until SOC gauge reads 7/8th or less, then plug vehicle into charger to bring SOC to 100%.
**If SOC falls below 40%	Plug vehicle into charger to bring SOC to 100%. Check SOC every 14 days.

Information

INFORMATION

Battery Monitoring System

The vehicle is equipped with passive battery balancing through the Battery Monitoring System (BMS). The Energy Storage System (ESS) consists of 408 total individual battery cells, which function as individual fuel tanks. These cells must be balanced to avoid unused energy or capacity.

Passive battery balancing turns on for the final 10 percent of a charge session. The BMS will prevent the charge session from ending until the batteries are fully balanced. Since cell imbalance naturally occurs during operation, the vehicle needs at least one full charge session (100% charge) per week to maintain proper cell balance.

Once the vehicle starts the battery balancing process, try to avoid stopping the BMS. If the vehicle must be operated, press the “stop charge” button on the vehicle to stop the BMS.

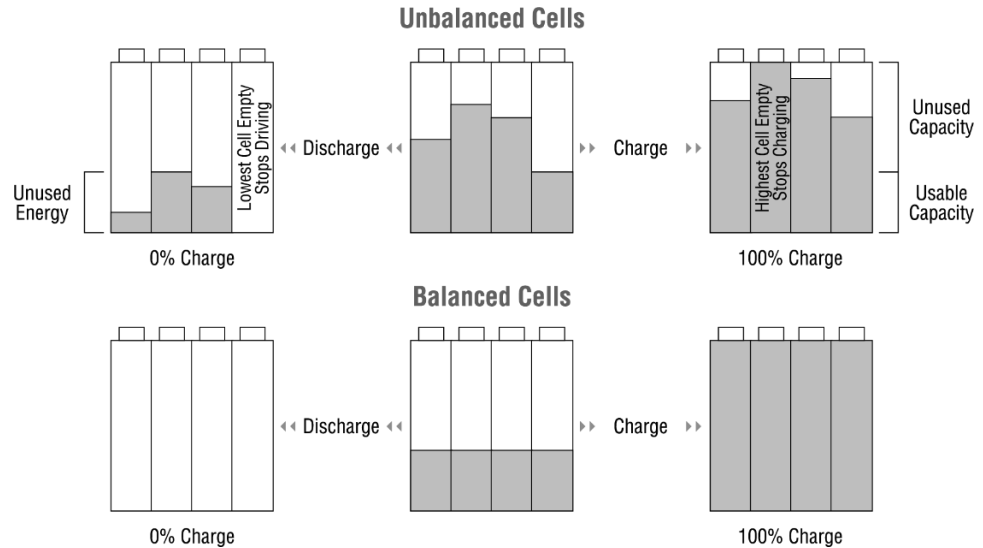

**NOTE**

For optimal performance and range, charge the high voltage batteries to 100% state of charge frequently, preferably at least once per week.

**NOTE**

The BMS system may be active for days at a time since the vehicle will continue the charge session until all batteries are fully balanced. The vehicle may display 95-99% charge during this time but will display 100% once all batteries are fully balanced.

Warranty Schedule

This Battery Electric Powertrain warranty schedule applies only to original factory equipment and is subject to the terms and limitations in the attached limited warranty agreement.

Pursuant to the terms of the attached Limited Warranty agreement, Peterbilt Truck Company will pay warranty claims for Warrantable Failures within the following maximum limits in time or mileage, whichever shall occur first. The Warrantable Failure must be brought to the attention of an Authorized Dealer within 30 days of discovery.

INFORMATION

Vehicle System	Months	Miles
Battery Electric Powertrain System [All other components not listed below] This coverage applies to the electric powertrain system, except for additional coverage and warranty exclusions.	12	100,000
eAxle Motor/Transmission/Carrier	36	300,000
ePowertrain	36	300,000
eAccessory Systems Air Compressor and Motor Power Steering Hydraulic Pump and Motor HVAC Compressor and Motor HVAC Heater and Pump	36	300,000
eControls Inverter Charger Unit (ICU) Powertrain Control Module (PCM) Supervisory Control Module (SCM) DC/DC Converter Cooling System Pump, Fans, Hoses, Radiator High Voltage Cables / Wiring Harness Charging Port	36	300,000
Battery / Energy Storage System (ESS) Battery Chiller	60	500,000 – OR – 80% Battery Capacity*
* “Battery Capacity” should be confirmed by connecting the designated Service Tool.		

PETERBILT MOTORS COMPANY

A PACCAR Company
P.O. Box 90208
Denton, Texas 76202

Do not remove the manual from vehicle.
Before operating vehicle study the manual carefully.
Read and understand all warnings, cautions and notes.

Need help? Give us a call 24 hours a day

1.800.4.PETERBILT



SCAN THIS QR CODE
TO ACCESS ONLINE
DRIVER RESOURCES.
peterbilt.com/driver-resources



Y53-6157-1C1

Printed in the U.S.A. 09/24